

# INSTALLATION INSTRUCTIONS

## P45AC6

### CAPACITY:

18,000 lbs. Maximum Vertical Load  
 90,000 lbs. Maximum Gross Trailer Weight  
 (120,000 lbs. tensile)

### DESCRIPTION:

Rigid type pintle hook with air actuated plunger. The plunger provides minimum clearance with some shock absorption.

**WARNING: MAINTAIN ADEQUATE VERTICAL (TONGUE) LOAD TO PROPERLY CONTROL THE TRAILER (APPROXIMATELY 10%). DO NOT EXCEED RATED CAPACITIES.**

### TOWING APPLICATIONS:

Trailers, full trailers, and doubles operating within the stated capacities. Reduce capacities by 25% for off road applications and use with swivel type drawbar.

### DRAWBAR EYE DIMENSIONS:

2-3/8" TO 3" I.D. with 1-5/8" TO 1-3/4" section.

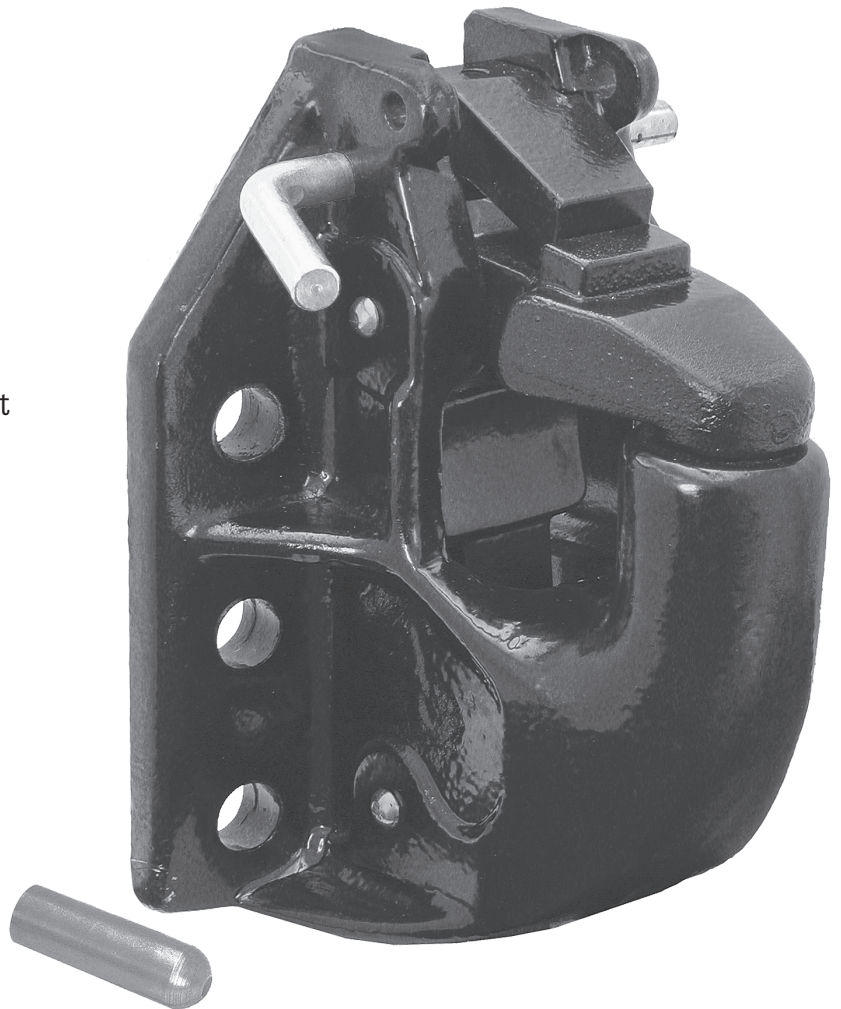
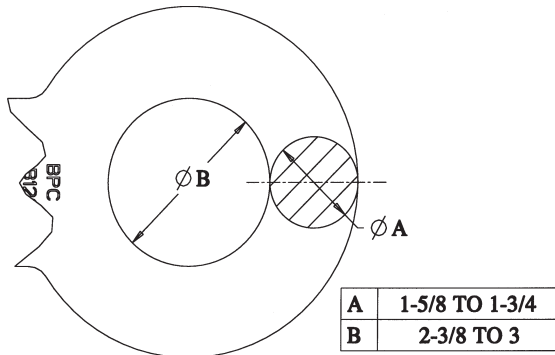

### MOUNTING INSTRUCTIONS:

**WARNING: THIS HITCH MUST BE USED WITH AN AIR BRAKE CHAMBER.**

1. Use a mounting structure of sufficient strength to support the rated capacity of the pintle hook in accordance with SAE J849B.
2. Use hole pattern dimensions described later in this sheet.
3. Determine the cut length for the air chamber rod and cut rod (see steps 3a & 3b.) Assemble jam nut to the rod before cutting and remove after cutting to clean up any damaged threads.

3a. When using Buyers mount bracket part no. P45AC6BK determine the cut length as follows:

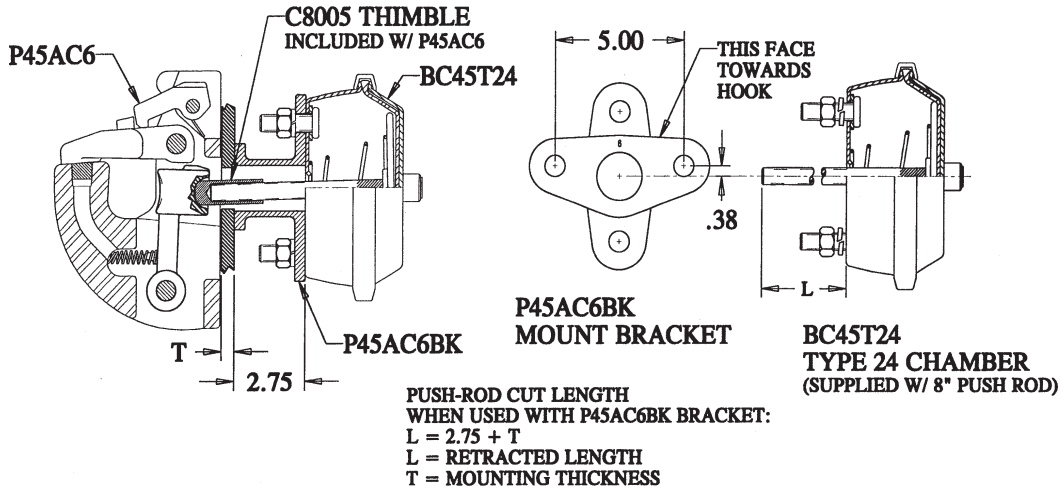

3b. When using any other air chamber mounting structure determine the cut length as follows:

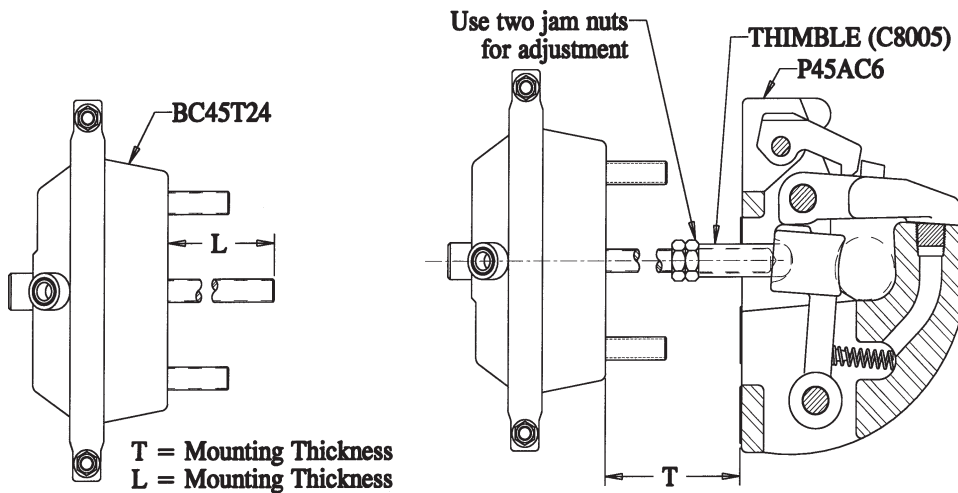

4. Assemble the air chamber to the P45AC6BK mount bracket or custom mount structure. Torque fasteners to 133-155 ft lbs.
5. Install pintle hook four 3/4" grade 8 screws and nuts in the hitch's bottom four holes and hand tighten. Assemble thimble to the end of the chamber rod. Assemble the air chamber assembly to hitch using the top two holes and two more 3/4" grade 8 screws. Tighten all screws properly. Torque plain screws to 375 ft-lbs. and plated screws to 275 ft-lbs.
6. Check hitch for proper operation by extending and retracting plunger.

**OPERATING INSTRUCTIONS:**

1. Before operating, inspect hitch assembly for proper operation, worn, damaged or missing parts. Correct any flaws before use.
2. Verify that the plunger is retracted. Release air pressure to retract plunger if necessary.
3. Open latch by pulling handle and rotating it upward. While holding the handle up lift the jaw and hook it open on the lock.
4. Lower drawbar eye over the horn of the pintle.
5. Close jaw and lock. Verify that the lock sides completely into its pocket.

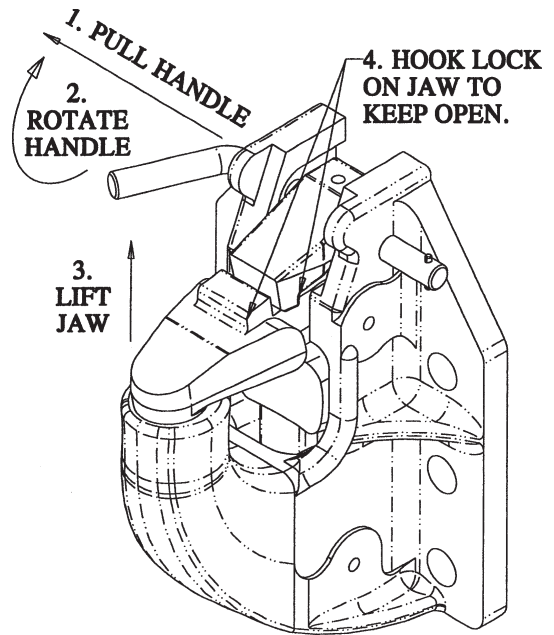

**WARNING: OTHER STEPS AND INSPECTIONS ARE ALSO REQUIRED. CONSULT D.O.T. REGULATIONS AND AMERICAN TRUCKING ASSOCIATION FOR COMPLETE COUPLING AND UNCOUPLING PROCEDURES.**

**MAINTENANCE:**

1. Clean and check for proper operation.
2. Inspect and replace worn, damaged, or missing parts.
3. Keep all pivot points well lubricated with light oil.
4. Check mounting bolts for proper torque.
5. Check for proper plunger adjustment.

**GENERAL DIMENSIONS:**

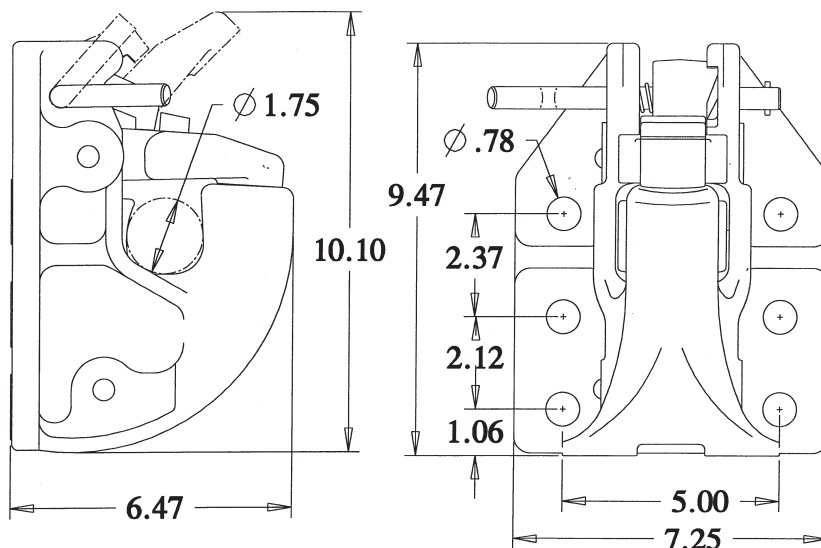

**HOLE PATTERN:**

Pattern drawing not to size.

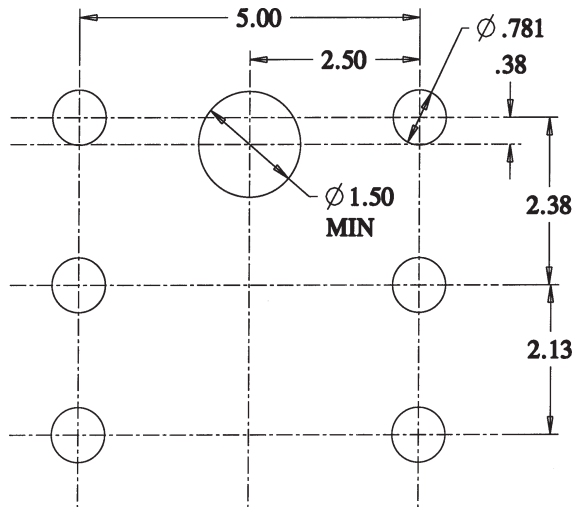

**REPLACEMENT PARTS KITS:**

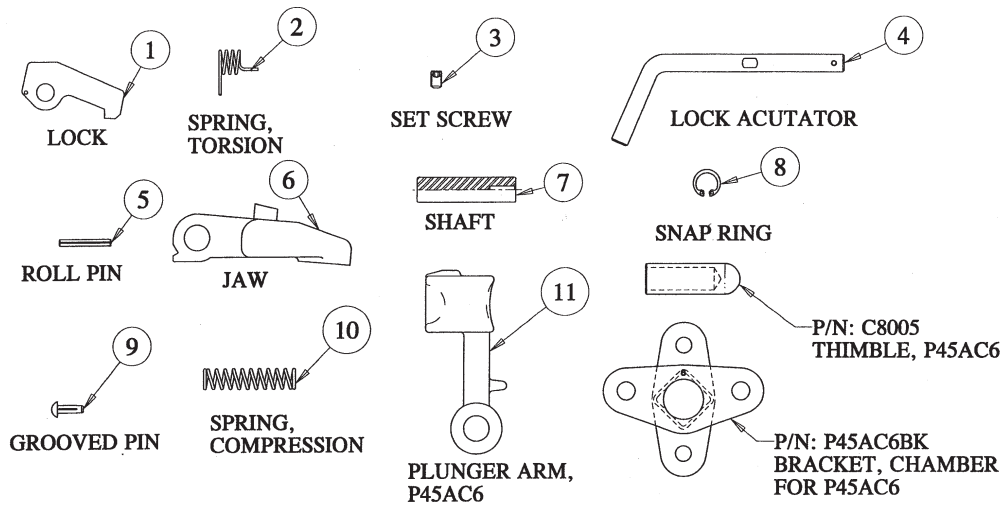

REPLACEMENT PART KITS		ITEM QUANTITY										
KIT NO:	DESCRIPTION	1	2	3	4	5	6	7	8	9	10	11
C6200	KIT, P45AC6 JAW REPLACEMENT	-	-	-	-	1	1	2	2	2	1	1
C6300	KIT, P45AC6 LOCK REPLACEMENT	1	1	1	-	1	-	-	-	-	-	-
C6400	KIT, P45AC6 REBUILD	1	1	1	1	1	1	2	2	2	1	1